



Phase Matrix, Inc.[®]
A National Instruments Company

QuickSyn[®]

MICROWAVE FREQUENCY SYNTHESIZERS

Models FSW-0010
FSW-0020

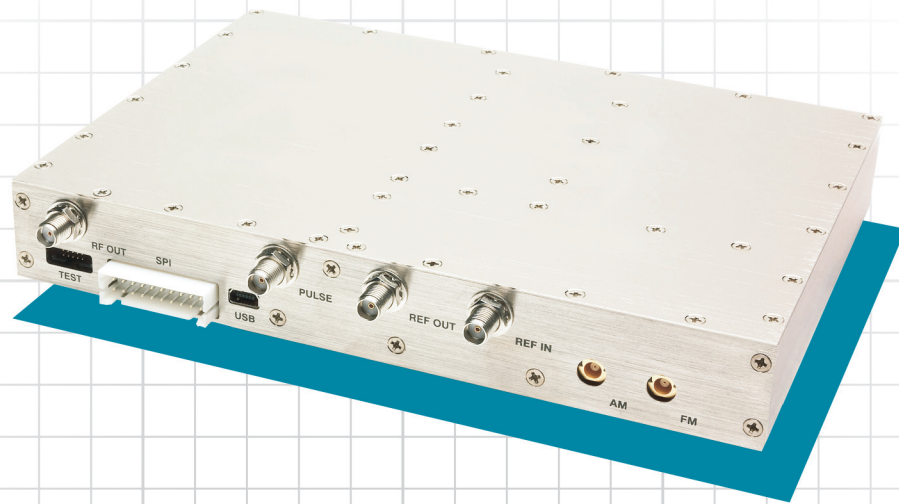

Features:

- 0.1 to 10 GHz and 0.2 to 20 GHz Coverage
- 0.001 Hz Resolution
- Power Calibration and Control
- 100 μ s Frequency Switching
- Instrument-Grade Spectral Purity

QuickSyn®

MICROWAVE FREQUENCY SYNTHESIZERS

Models FSW-0010
FSW-0020

Features

- Wide frequency coverage
- Fundamental signal output
- Sub-Hz resolution
- Microsecond switching speed
- Instrument-grade spectral purity
- Output power control
- Freq. and power sweep, list mode
- Multiple modulation options
- Compact size



The QuickSyn® synthesizer is easily deployed.

Technology

QuickSyn® microwave synthesizers deliver instrument-grade performance, increased functionality, and efficient power consumption at a reduced size and low cost. The synthesizers employ a patented, revolutionary phase-refining technology that provides a unique combination of fast-switching speed and low phase-noise characteristics.

Models FSW-0010 and FSW-0020 cover the frequency ranges of 0.5 to 10 GHz and 0.5 to 20 GHz respectively (extendable down to 0.1 GHz and 0.2 GHz). QuickSyn® synthesizers utilize

a fundamental VCO to achieve the desired output frequency. In contrast to frequency multiplication schemes, this approach eliminates possible spectrum contamination from subharmonic products. The use of the advanced direct digital synthesis approach, enables a very fine frequency resolution of 0.001 Hz. The VCO noise is suppressed by utilizing an ultra low noise reference oscillator in conjunction with a low-noise locking mechanism. Microphonic effects are also greatly reduced due to the use of a low-mass VCO and very wide PLL filter bandwidth.

Front View

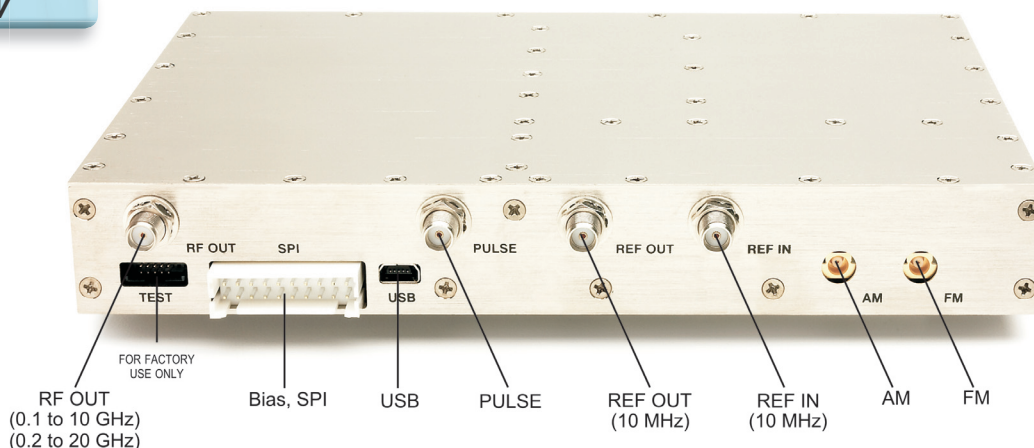

QuickSyn®

MICROWAVE FREQUENCY SYNTHESIZERS

Models FSW-0010
FSW-0020

Specifications and ordering information subject to change without notice.

Specifications

FREQUENCY

DESCRIPTION	SPECIFICATION (FSW-0010 / FSW-0020)
Frequency Range ①	0.5 to 10 GHz / 0.5 to 20 GHz
Frequency Resolution	0.001 Hz
Frequency Stability	Same as reference
Frequency Switching Time (full band step, to ± 50 kHz of final frequency)	
Standard Unit	1 ms (in all modes)
With Option 03	100 μ s (triggered list mode) 200 μ s (individual SPI commands)
List Mode	32,000 points, separate control of freq., power, RF output mute, and pulse modulation

OUTPUT POWER

DESCRIPTION	SPECIFICATION (FSW-0010 / FSW-0020)
Power	+15 dBm / +13 dBm
Power Accuracy	± 2.0 dB typ.
With Option 02	
Power Control Range ②	-25 to +15 dBm / -10 to +13 dBm
Power Resolution ②	0.10 dB nom.
Power Mute	-65 dBm max.
Output Return Loss	-10 dB nom.

SPECTRAL PURITY③

DESCRIPTION	SPECIFICATION (FSW-0010 / FSW-0020)				
Harmonics	-45 dBc typ. / -35 dBc typ.				
Non-Harmonic Spurious	-75 dBc typ. / -70 dBc typ. -65 dBc max. / -60 dBc max.				
Phase Noise	dBc / Hz				
	0.5 GHz typ (max.)	1 GHz typ (max.)	5 GHz typ (max.)	10 GHz typ (max.)	20 GHz typ (max.)
100 Hz	-109 (-103)	-103 (-97)	-89 (-83)	-83 (-77)	-77 (-71)
1 kHz	-135 (-132)	-132 (-126)	-118 (-112)	-112 (-106)	-106 (-100)
10 kHz	-144 (-139)	-138 (-133)	-128 (-123)	-122 (-117)	-116 (-111)
100 kHz	-144 (-139)	-138 (-133)	-128 (-123)	-122 (-117)	-116 (-111)
1 MHz	-146 (-141)	-140 (-135)	-132 (-127)	-126 (-121)	-120 (-115)
Floor	-151 (-147)	-150 (-147)	-150 (-147)	-150 (-147)	-150 (-147)

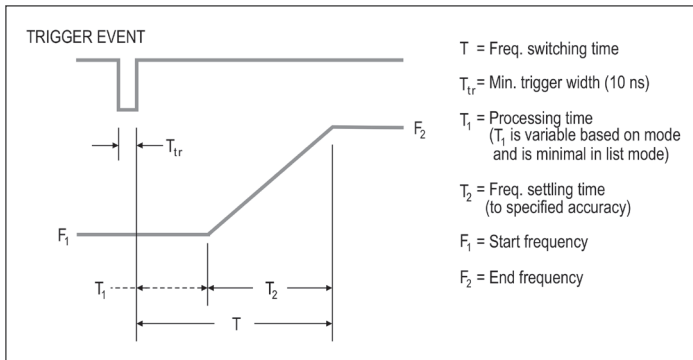

Frequency Switching Speed

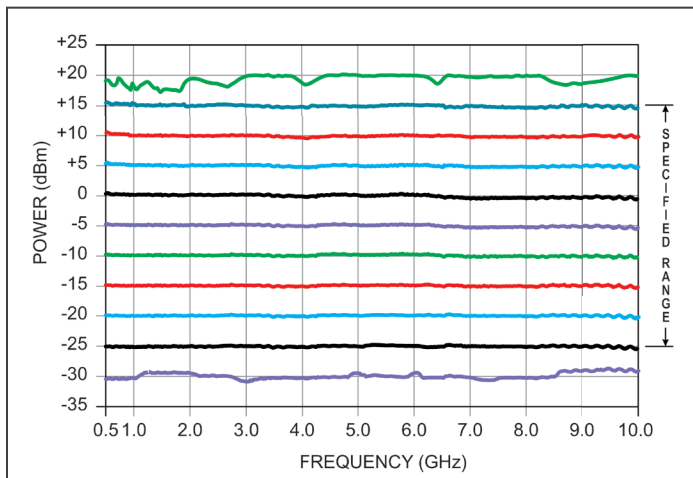

Output Power of an FSW-0010

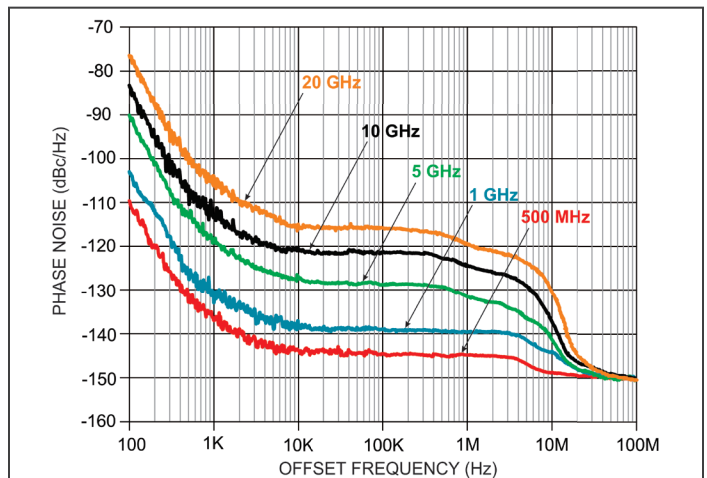

Phase Noise

QuickSyn®

MICROWAVE FREQUENCY SYNTHESIZERS

Models FSW-0010
FSW-0020

Specifications and ordering information subject to change without notice.

Specifications (continued)

MODULATION

DESCRIPTION	SPECIFICATION (FSW-0010 / FSW-0020)
-------------	-------------------------------------

Pulse Modulation ③

On/Off Ratio	80 dB min.
--------------	------------

Repetition Frequency Range	DC to 10 MHz
----------------------------	--------------

Min. Pulse Width	50 ns nom.
------------------	------------

Width Compression	< 15 ns nom.
-------------------	--------------

Delay Time	< 35 ns nom.
------------	--------------

Rise/Fall Time (10 to 90%)	10 ns max.
----------------------------	------------

Pulse Overshoot	10% max.
-----------------	----------

Input Level	CMOS (+5 V = RF on, 0 V = RF off)
-------------	-----------------------------------

Absolute Max. Input Level	+6 V
---------------------------	------

Input Impedance	100 kΩ (pulled up to +5 V)
-----------------	----------------------------

Amplitude Modulation (AM) ②

Rate Range	DC to 100 kHz
------------	---------------

Modulation Depth ④	40 dB min. / 20 dB min.
--------------------	-------------------------

Sensitivity ⑤	user settable
---------------	---------------

Absolute Max. Input Level	± 2 V (4 V p-p)
---------------------------	-----------------

Input Impedance	50 Ω nom.
-----------------	-----------

Frequency Modulation (FM)

NB 1 Mode Rate Range	100 Hz to 10 kHz
----------------------	------------------

NB 2 Mode Rate Range	10 kHz to 100 kHz
----------------------	-------------------

WB Mode Rate Range	50 kHz to 1 MHz
--------------------	-----------------

Phase Mode Rate Range	DC to 100 kHz
-----------------------	---------------

Sensitivity ⑤	user settable
---------------	---------------

Deviation	see note ⑥
-----------	------------

Absolute Max. Input Level	± 2 V (4 V p-p)
---------------------------	-----------------

Input Impedance	50 Ω nom.
-----------------	-----------

REFERENCE

DESCRIPTION	SPECIFICATION (FSW-0010 / FSW-0020)
-------------	-------------------------------------

Internal Reference

Output Frequency	10 MHz nom.
------------------	-------------

Output Power	+5 ± 2 dBm
--------------	------------

Reference Mute	-60 dBm max.
----------------	--------------

Frequency Temp. Stability	± 0.2 ppm (over 0° to 50° C)
---------------------------	------------------------------

Aging (after 30 days of operation)	± 1.25 ppm for 10 years
------------------------------------	-------------------------

Locking Range	± 2.0 ppm
---------------	-----------

Output Impedance	50 Ω nom.
------------------	-----------

External Reference

Input Frequency ⑦	10 MHz
-------------------	--------

Input Power	+5 ± 5 dBm
-------------	------------

Absolute Max. Input Level	+15 dBm
---------------------------	---------

Input Impedance	50 Ω nom.
-----------------	-----------

ELECTRICAL

DESCRIPTION	SPECIFICATION (FSW-0010 / FSW-0020)
-------------	-------------------------------------

Supply Voltage	+12.0 to +12.6 V DC
----------------	---------------------

Absolute Max. Supply Voltage	+15 V DC
------------------------------	----------

Power Consumption (warm up)	24 W max.
-----------------------------	-----------

Power Consumption (normal operation)	18 W nom. / 20 W nom.
--------------------------------------	-----------------------

GENERAL & ENVIRONMENTAL SPECIFICATIONS

DESCRIPTION	SPECIFICATION
-------------	---------------

Temperature Range ⑧

Operating	0° to +55° C
-----------	--------------

Non-Operating	-40° to +70° C
---------------	----------------

Warm-up Time	15 minutes
--------------	------------

QuickSyn®

MICROWAVE FREQUENCY SYNTHESIZERS

Models FSW-0010
FSW-0020

Specifications and ordering information subject to change without notice.

Specifications (continued)

MECHANICAL SPECIFICATIONS

DESCRIPTION	SPECIFICATION
Size (W x L x H)	5 x 7 x 1 in. (12.7 x 17.78 x 2.54 cm)
Weight	2.5 lb. (1.13 kg)
Connectors	See table

CONNECTOR TABLE (see front view on first page)

LABEL	TYPE
RF OUT	SMA-F
PULSE	SMA-F
REF OUT	SMA-F
REF IN	SMA-F
AM	MCX-F
FM	MCX-F
SPI	20 pin, 0.1 in. spaced double-row header
USB	Mini-B receptacle (USB 2.0)

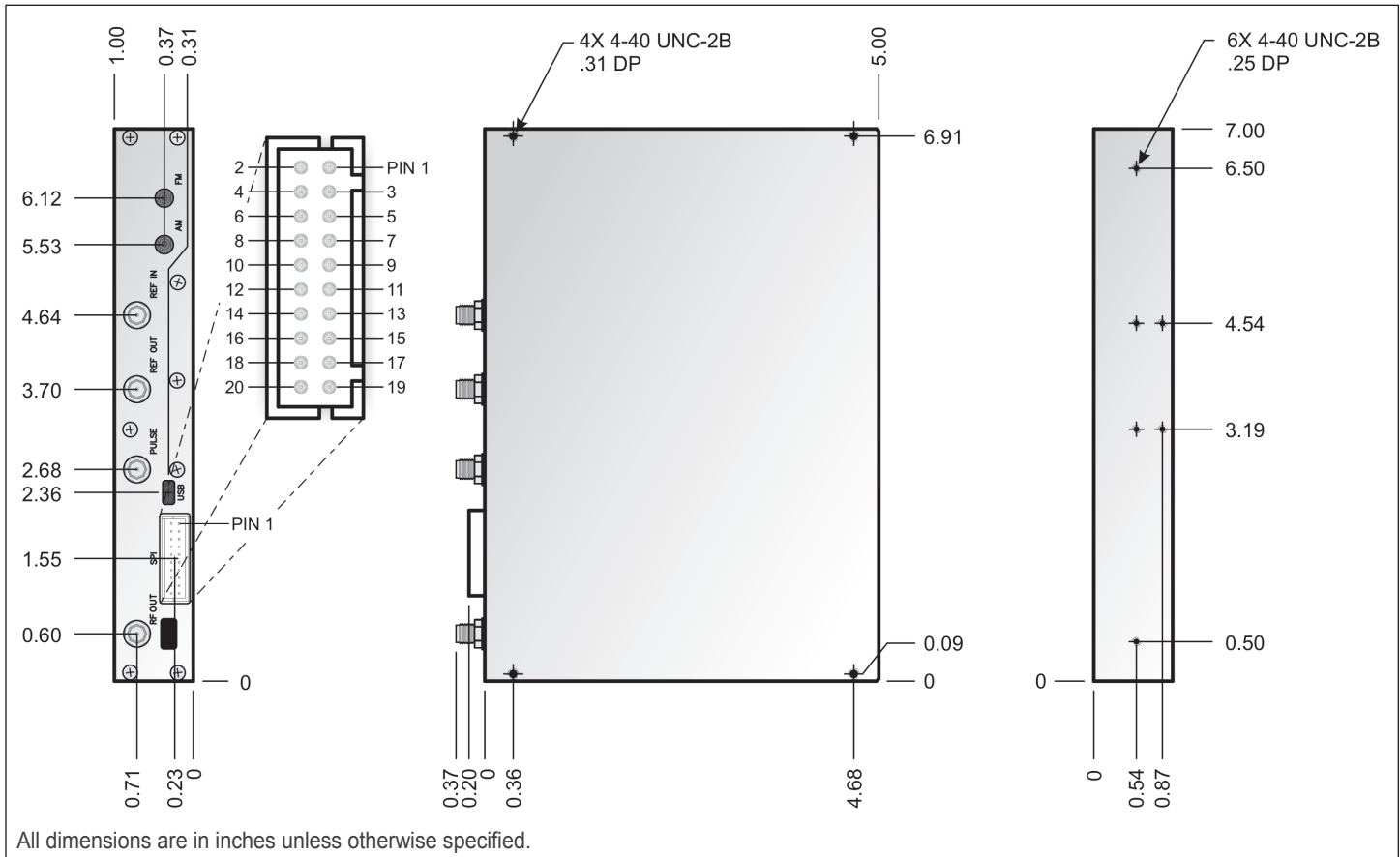

QuickSyn®

MICROWAVE FREQUENCY SYNTHESIZERS

Models FSW-0010
FSW-0020

Programming

SPI INTERFACE

SIGNAL	PIN	DESCRIPTION
SPI_CLK	11	SPI clock. Supplied by the controlling computer (not the synthesizer). The controlling computer is the SPI master; the synthesizer is the SPI slave.
SPI_SS	13	SPI Slave Select. This signal is an active low input to the synthesizer. It frames command communications. For each command, SPI_SS goes low before the first bit is sent and goes high after the last bit is sent.
SPI_MISO	7	Master In/Slave Out. Status and other returned information from the synthesizer to the controlling computer.
SPI_MOSI	9	Master Out/Slave In. Command data from the controlling computer to the synthesizer.
TRIGGER	17	Rising edge active input. When enabled, the trigger signal of +3.3 V can initiate freq. change or step through lists or sweeps.
LOCK	15	Output indicates the synthesizer is locked on its current setting (+3.3 V locked, 0 V unlocked).
REF_LOCK	16	Output indicates the synthesizer has detected an external reference signal and locked on that signal (+3.3 V locked, 0 V unlocked).
RESET	18	Internally pulled up to +3.3 V with 100 kΩ resistor. Active “low” signal, which has a minimum width of 1 ms, will reset the synthesizer to a default state.
PWR_+12V	3, 4	External +12V DC supply.
GND	8, 10, 19, 20	Ground.
N/C	1, 2, 5, 6, 12, 14	Do not use. Reserved for factory use.

PROGRAMMING

See QuickSyn® Communications Specification located on the Phase Matrix website (www.phasematrix.com)

SPI TIMING

DESCRIPTION	SPECIFICATION
$T_{SC} > 25$ ns	Slave select low before first CLK
$T_{CS} > 25$ ns	CLK low before slave select high
$T_{SU} > 15$ ns	Data stable before rising edge of CLK
$T_{CH} > 25$ ns	Minimum CLK high time
$T_{CL} > 25$ ns	Minimum CLK low time
$F_{CLK} \leq 12$ MHz	Maximum CLK frequency

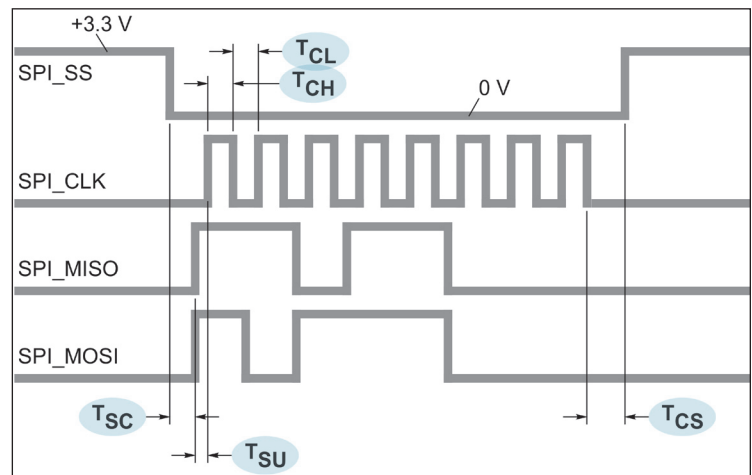

MICROWAVE FREQUENCY SYNTHESIZERS

Models FSW-0010
FSW-0020

Software User Interface

A simple software user interface allows utilization of a number of sophisticated functions such as precise frequency and power control, RF output and reference mute, blanking, independent frequency and power sweeps, list mode, modulation, and many others. Software and user's manual are available for download on the Phase Matrix website (www.phasematrix.com).

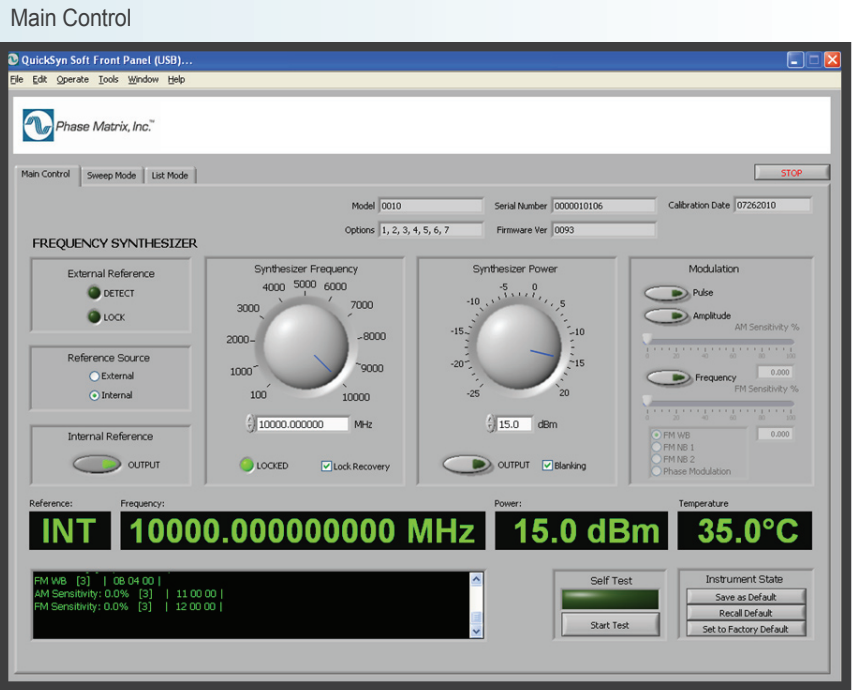

Sweep Mode

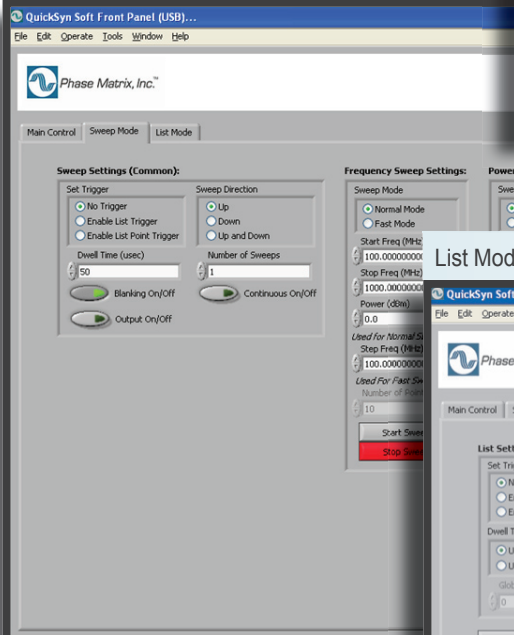

List Mode

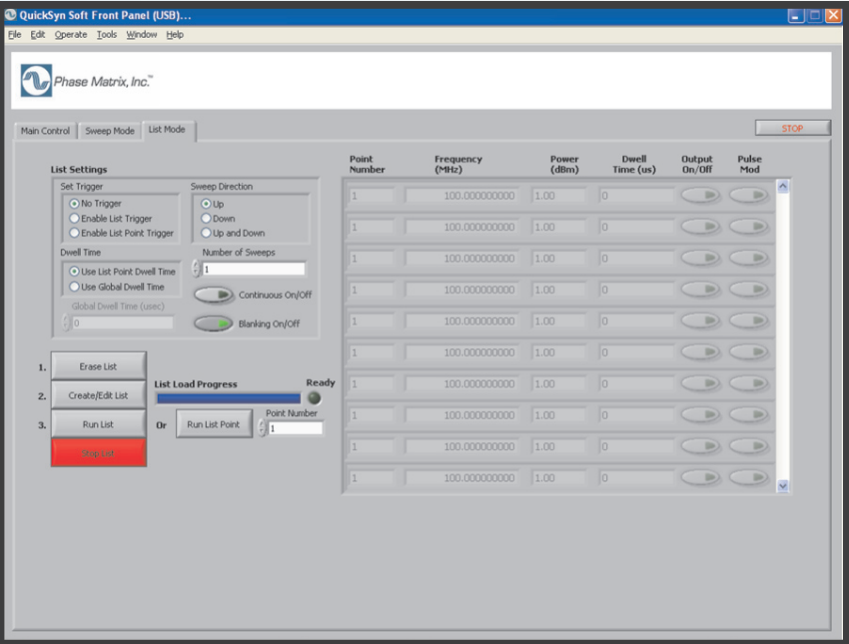

QuickSyn®

MICROWAVE FREQUENCY SYNTHESIZERS

Models FSW-0010
FSW-0020

ORDERING INFORMATION

Models	FSW-0010, FSW-0020
Options	
Option 01	0.1 GHz output frequency extension ❶ (FSW-0010) 0.2 GHz output frequency extension ❶ (FSW-0020)
Option 02	Power control, -25 to +15 dBm (FSW-0010) Power control, -10 to +13 dBm (FSW-0020)
Option 03	Fast-switching (<i>any frequency to any frequency</i>) 100 μ s max. (to \pm 50 kHz in ext. triggered list mode) 200 μ s max. (to \pm 50 kHz regular SPI control)
Option 04	USB interface
Option 05	Pulse modulation
Option 06	Amplitude modulation ❷
Option 07	Frequency and phase modulation

Accessories	
01	Cable, AM/FM (BNC-M to MCX-M)
02	Cable, USB
03	Cable, DC bias
04	Test report
05	SPI mating connector with contacts ❸
06	QuickStart kit (Includes all the cables necessary, power supply, and a helpful guide to start off right with the QuickSyn® synthesizer)
07	Kit, cable, RS232 (interface adapter)
08	Kit, Ethernet adapter (interface adapter)
09	Kit, GPIB adapter (interface adapter)

Notes:

- ❶ Frequency extension down to 0.1 GHz (FSW-0010) and 0.2 GHz (FSW-0020) are available as option 1. Output power between 0.1 and 0.5 GHz is limited at +10 dBm. Harmonics may increase below 0.5 GHz.
- ❷ Available with option 2 only. Power accuracy may change at low power levels.
- ❸ Measured at maximum specified power.
- ❹ Measured with power set at mid range. AM is clipped when available power (min. or max.) is reached.
- ❺ AM and FM sensitivity is dependent on synthesizer output frequency and is controllable by software.
- ❻ The amplitude of the FM input signal must be adjusted to obtain the desired deviation according to the output frequency range.
- ❼ External reference frequency input to be within \pm 2 ppm max.
- ❽ Adequate heat sinking must be provided in order to prevent permanent damage.
- ❾ Phase Matrix recommends Hirose manufactured socket DF1B-20DS-2.5RC and contacts DF1B-2022SC.
- ❿ "Typ." means approximately 2/3 of all units meet these characteristics at room temperature. Characteristics identified by typ. and nom. are by design and are not normally verified on every unit during production.

Warranty

Phase Matrix, Inc. has a proven commitment to quality and reliability in instrumentation. This commitment is demonstrated in the QuickSyn® series of synthesizers with a full one-year standard warranty. Parts, labor, and even shipping are all included at no cost to you.

Phase Matrix, Inc. designs and manufactures RF and microwave test-and-measurement (T&M) instruments, subsystems, and components and is a wholly owned subsidiary of National Instruments Corporation. Our array of instruments includes traditional benchtop frequency counters, modular (VXI) pulsed-frequency counters, modular (VXI and PXI) synthetic instruments, including downconverters, upconverters/synthesizers and local oscillators that are designed for both commercial and military applications. In addition, we produce instrument-grade, fast-switching synthesizer modules that can be used in various instruments or subsystems. We also manufacture a line of narrowband and broadband microwave components, ranging from VCOs to complex custom-built assemblies for military instrumentation and telecommunications applications

Data sheet PN: DS_FSW-0010-0020 Rev. D

Copyright © 2013 Phase Matrix, Inc. All rights reserved.

Phase Matrix, Inc. ○ 4600 Patrick Henry Drive, Santa Clara CA 95054 ○ Tel: 1-610-6810 ○ www.phasematrix.com